

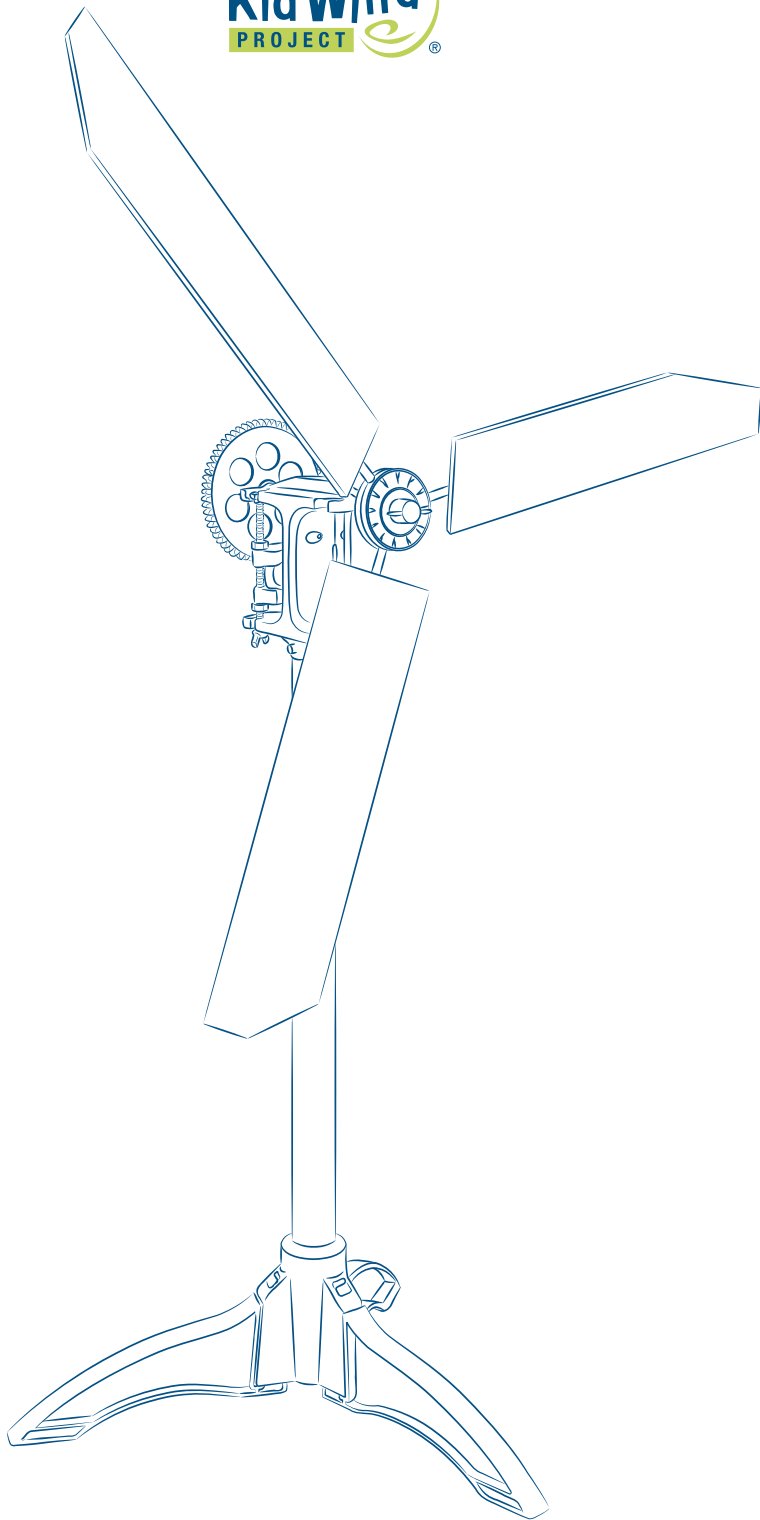

# Advanced Wind Experiment Kit



*instructions*

## About KidWind

The KidWind Project is a team of teachers, students, engineers, and practitioners exploring the science behind wind energy in classrooms around the US. Our goal is to introduce as many people as possible to the elegance of renewable energy through hands-on science activities which are challenging, engaging, and teach basic science principles.

While improving science education is our main goal, we also aim to help schools become important resources for both students and the general public, to learn about and see renewable energy in action.

## Thanks to ...

We would like to thank the Wright Center for Science Education at Tufts University for giving us the time and space to develop this idea into a useful project for thousands of teachers.

We would also like to thank Trudy Forsyth at the National Wind Technology Center and Richard Michaud at the Boston Office of the Department of Energy for having the vision and foresight to help establish the KidWind Project in 2004. Lastly, we would like to thank all the teachers for their keen insight and feedback on making our kits and materials first rate!

## Wind for All

At KidWind, we strongly believe that K–12 education is an important foundation for promoting a more robust understanding of the opportunities and challenges that emerging clean energy technologies present.

The Wind for All program seeks to support teachers and students all over the globe who do not have the financial capacity to access our training programs and equipment. We believe that all teachers and students—regardless of where they live or what school they attend—must be part of the clean energy future.

## A Note on Reproduction

This work may not be reproduced by mechanical or electronic means without written permission from KidWind, except for educational uses by teachers in a classroom situation or a teacher training workshop. For permission to copy portions or all of this material for other purposes, such as for inclusion in other documents, please contact Michael Arquin at KidWind: michael@KidWind.org

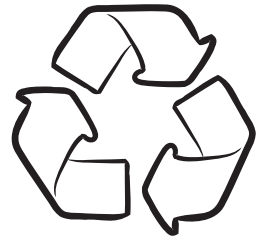

Our plastic components are made from recycled resins.



Made in US

We source domestically whenever possible, and assemble and pack our kits in St. Paul, MN.

**We  
Give  
Back** 

Proceeds from your purchase help us train and supply teachers.

V1.0

These instructions will show you how to build the Adaptable Learning Turbine. While some parts come pre-assembled, you will have to put a few things together to finish the job. This turbine allows for maximum variability and experimentation while dramatically increasing power output through the use of a gear box.

## *Cool features of the Advanced Wind*

### *Experiment Kit*

The Advanced Wind Experiment Kit is our most powerful, adaptable and experimentally rich turbine. It is also our most eco-friendly design—using all recycled plastics!

#### **Adaptable**

- Interchangeable gear ratios—up to 8:1
- Ability to test electricity production and weightlifting
- Interchangeable generators—test different DC motors
- Easily converted to a Vertical Axis Wind Turbine
- Can fit two generators and/or rotors at the same time (*more power!*)
- Can be used to build your own AC generator with the KidWind GENPack (a separate add-on)

#### **Renewable**

- Forest Stewardship Council (FSC) certified renewable wood tower
- All plastic parts made from recycled plastic!

Use your Advanced Wind Experiment Kit to power a variety of load devices:

- Fuel cells
- LEDs
- Incandescent bulbs
- Mini water pumps
- Small motors
- Supercapacitors

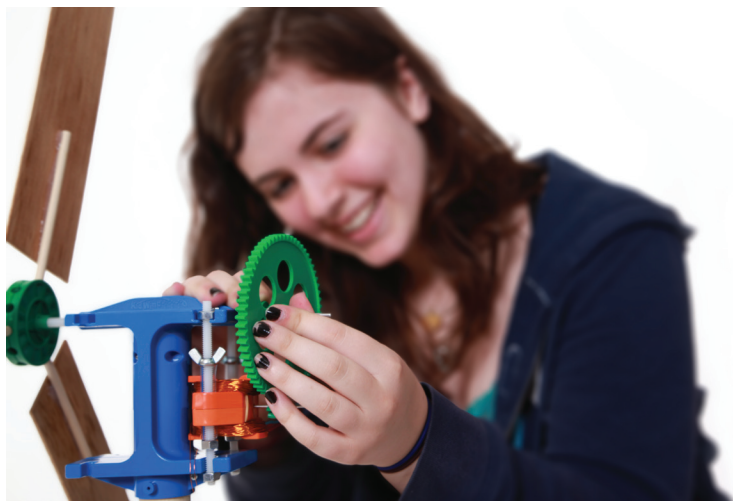

# Advanced Wind Experiment Kit Parts

## Nacelle



SCREWS

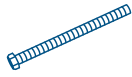

BOLTS



WING NUTS



NUTS

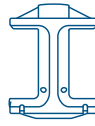

NACELLE HALVES



MOTOR MOUNTS

## Blades



BLADE PITCH  
PROTRACTOR

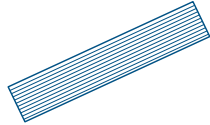

16 IN. CORRUGATED  
PLASTIC SHEETS

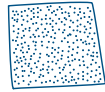

SANDPAPER



1/4 IN. DOWELS

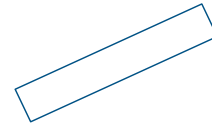

18 IN. BALSA  
WOOD SHEETS

## Tower



BASE CENTER



LEGS

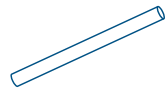

20 IN. WOOD  
TOWER



TOWER LOCK  
DISC

## Drivetrains

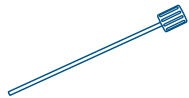

HUB QUICK CONNECT  
& DRIVESHAFT



WIND TURBINE  
MOTOR



HEX LOCKS



WIND TURBINE  
HUB

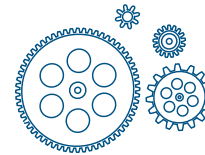

GEARS



SPOOL



HIGH TORQUE  
MOTOR

## Output Devices



LED BULBS



INCANDESCENT BULBS



SUPERCAPACITOR

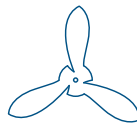

PROPELLER



PLASTIC BUCKET



4 FT. STRING



WASHERS

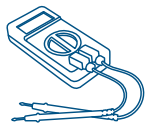

DIGITAL MULTIMETER

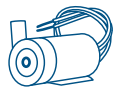

WATER PUMP

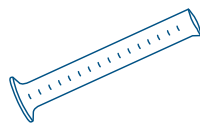

GRADUATED CYLINDER



RESISTORS



ALLIGATOR CLIP CORDS



WIND TURBINE  
MOTOR

## Construction

### *KidWind tower assembly*

The turbine tower is made of six pieces:

- 1 Wood tower
- 1 Center hub
- 1 Locking disk
- 3 Legs

1. Lock one leg onto the center hub.
2. Attach the two other legs in the same way.
3. Slide the locking disk onto the tower about 6 inches from the bottom end.
4. With the teeth of the locking disk pointing down, insert the tower into the center hub.
5. Slide the locking disk down the tower and into the hub, locking the tower in place.

To disassemble the legs, you can use one of your  $\frac{1}{4}$ " dowels as a lever. Insert it into the gap on the leg below the hub and push it away. The leg will pop right off!



**CHECK OUT ONLINE VIDEOS FOR HELP!**

*For help with assembling and disassembling the tower and base, watch a quick video at [www.KidWind.org/videos](http://www.KidWind.org/videos)*

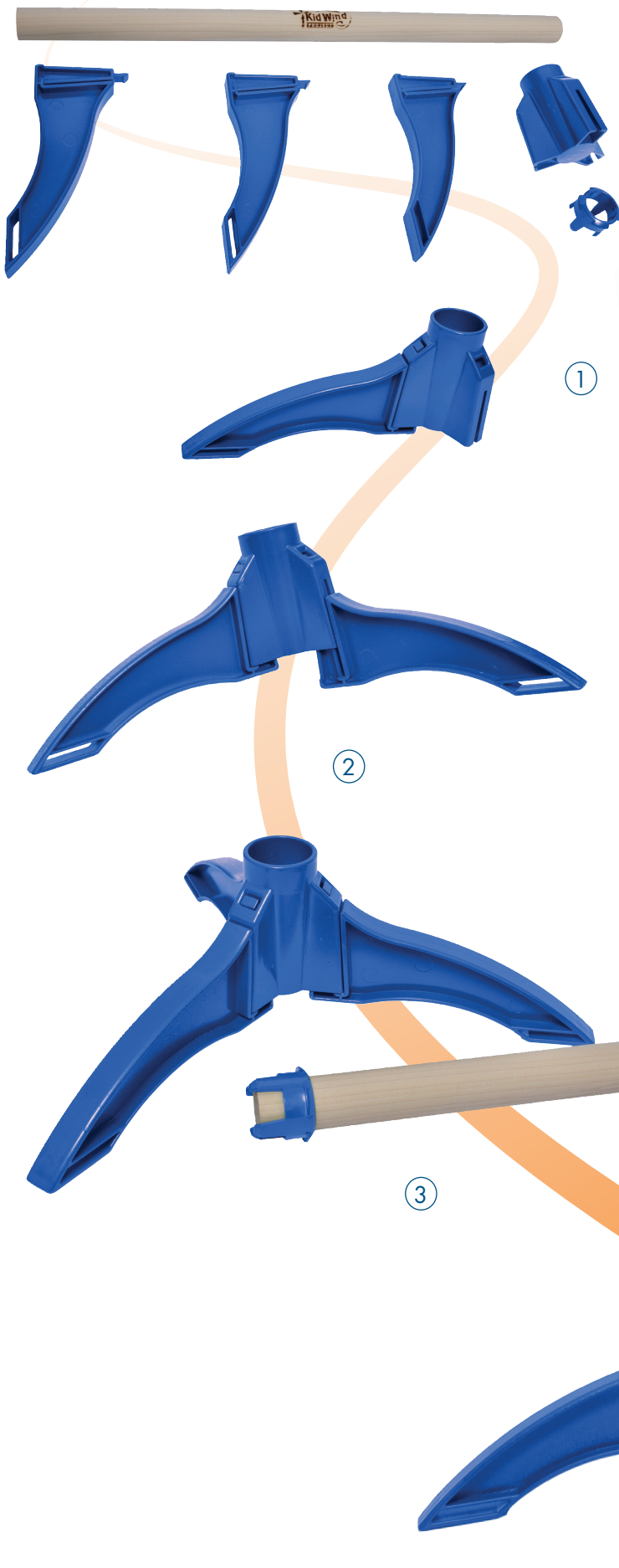

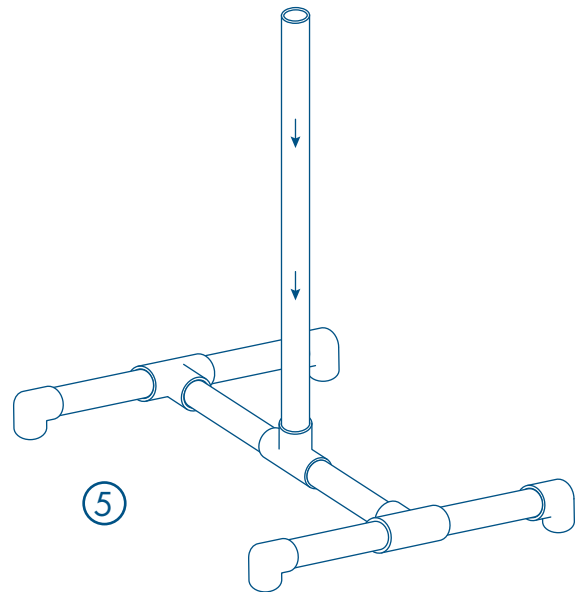
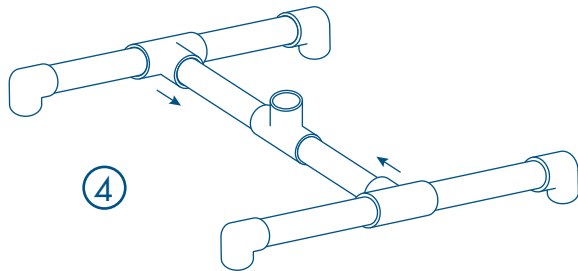
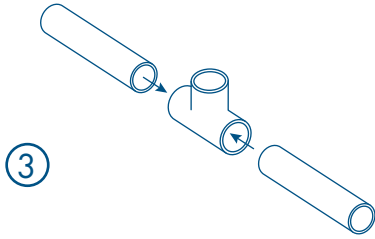
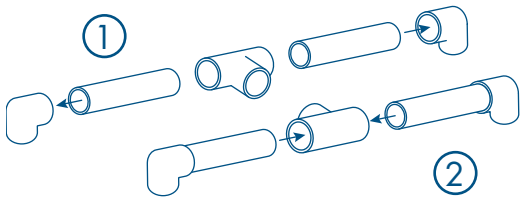

## DIY PVC tower

KidWind's first turbines all had towers and bases made from PVC pipe. It's cheap, sturdy and available everywhere. Unfortunately, the production of polyvinyl chloride also results in carcinogens and mutagens, which can also be released if the product is incinerated. In keeping with our commitment to the environment, we are phasing out PVC in our products.

However, we are also committed to making renewable energy science accessible, so we continue to sell affordable DIY kits, which require our customers to build their own tower and base. If you choose to use PVC pipe, follow these instructions to easily build your own.

### Parts needed

All PVC is 1" diameter, schedule 40.

- 4 90° PVC fittings
- 6 6" PVC pipe sections
- 3 PVC T-fittings; drill a small hole in one "T"
- 1 24" PVC pipe section

### Instructions

1. Insert one 6" piece of PVC into each of the 90° PVC fittings.
2. Use each of the PVC T's as a connector for two of the pieces you constructed in step one. When assembled, the pieces should form a straight line. The open ends of the T's should be positioned parallel to the ground and facing each other.
3. To construct the leg connector portion, insert the two remaining sections of 6" PVC into the remaining PVC T-fitting so that the open end of the T is pointing upwards and the pipes form a straight line.
4. To finish constructing the base of your tower, insert the open pipe ends of the leg connector portion into the open ends of the PVC T-fittings in the leg halves.
5. Finally, insert the 24" PVC pipe into the open and upwards-facing portion of the leg connector's PVC T. Straighten all parts and make sure joints are secure.

Fit the parts together without using glue. (PVC glue is really nasty stuff.) To make them fit snugly, tap them together with a hammer or bang them on the floor once they are assembled.

### NO NEED TO GLUE

*It is not necessary to glue the joints. PVC glue is nasty stuff. Omitting glue out also lets you take the tower apart for storage.*

## Building the nacelle

1. Take the 2 identical molded nacelle parts and fit them together. Each side has 3 small holes. Secure the two sides together by screwing 6 small screws into these holes.
2. Take a hex nut and screw it about  $\frac{2}{3}$  of the way up the 4" bolt. Next, slide the 2 motor mount sections up the bolt such that the two concave sections are facing each other (see picture). Then screw another hex nut onto the bolt under the mounts.
3. Notice that the top of the nacelle has cutouts shaped for the top of the bolts. Slide the bolt (with nuts & mount) into the cutouts. Then attach a hex nut onto the bottom of the bolt so that it is secured to the nacelle.
4. Now take the second 4" bolt and screw a wingnut about  $\frac{1}{3}$  of the way up. Slide that bolt into the top cutout and through the motor mounts. Take a hex nut and screw it onto the bolt under the mounts. Move the wingnut up the bolt so that you can slide the bolt all the way down to the bottom cut-out. Now secure the second bolt with another hex nut as you did with the first bolt.
5. Secure all the nuts and bolts so that the nacelle is tight and secure. Be careful not to over-tighten the wingnuts on the bottom of the nacelle, or you will bend the nacelle. Over tightening probably will not break anything, but can make your turbine less efficient.

The wingnuts and hex nuts may be used interchangeably in constructing the nacelle. While wingnuts are easier to adjust, the smaller size of the hex nuts allows for more variable configurations.

## Advanced Wind Experiment Kit gears and motors

1. Now you are ready to attach a generator to the nacelle. Choose a DC motor to use as your generator and loosen the motor mounts on the nacelle until you can fit the motor between them. Then tighten the nuts down onto the motor mount to hold the motor securely in place.  
  
Optional: If you are using a PVC tower, you can snake the wires from the motor through the slot in the nacelle behind the motor mount. Then the wires can go down through the PVC pipe. On a wood tower, the wires can go out the side of the nacelle. You can attach the wires to the wood tower with zip-ties or tape.
2. Attach the smallest gear (pinion) to the driveshaft of the DC motor. The small hole in this gear should friction fit on small DC motor driveshafts.
3. Slide the driveshaft with attached Hub Quick Connect into the hole at the top of the nacelle. You may need to wiggle or rotate the driveshaft as you push it in. Slip a hex lock onto the driveshaft with the collar facing the nacelle.

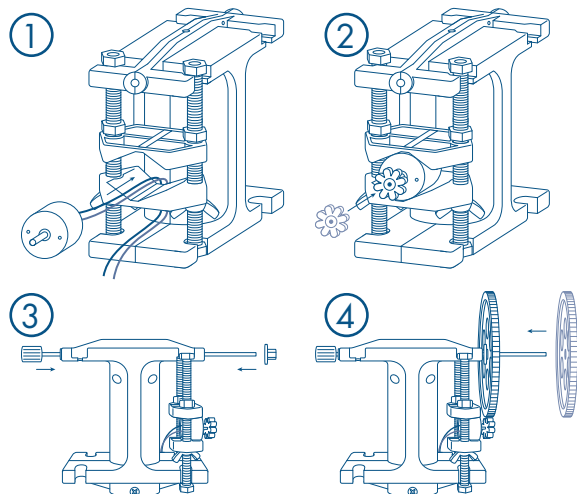
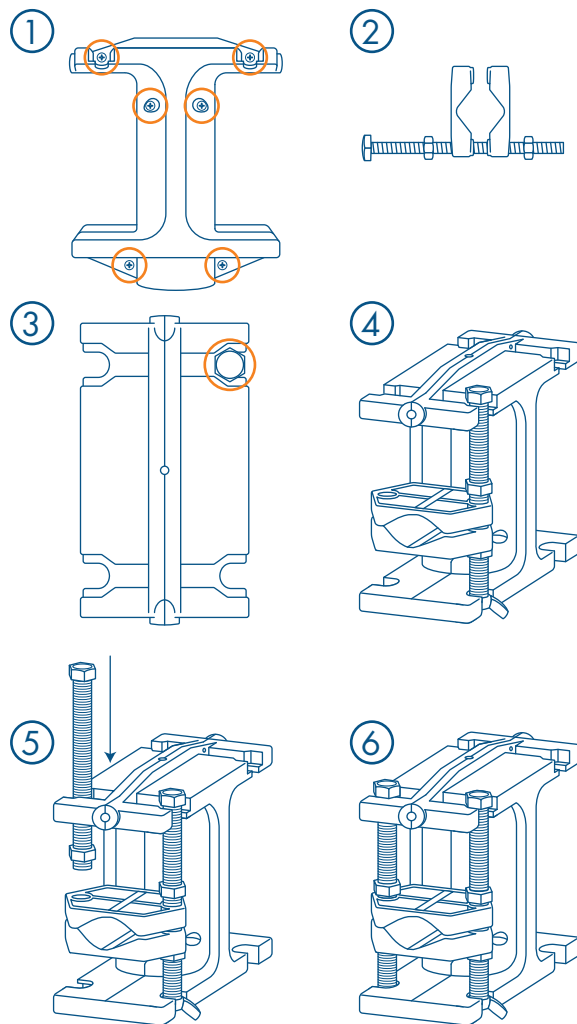

**CHECK OUT ONLINE VIDEOS FOR HELP!**

*For help with assembling the Advanced Wind Experiment Kit nacelle, watch a quick video at [www.KidWind.org/videos](http://www.KidWind.org/videos)*

Hold the HCQ with one hand, while pulling off the KidWind Hub.

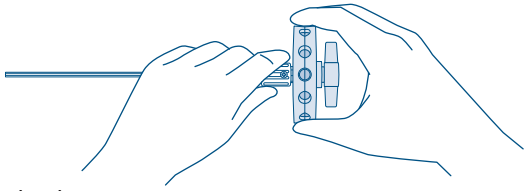

Like this!

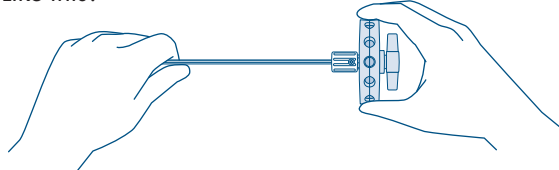

Not like this!

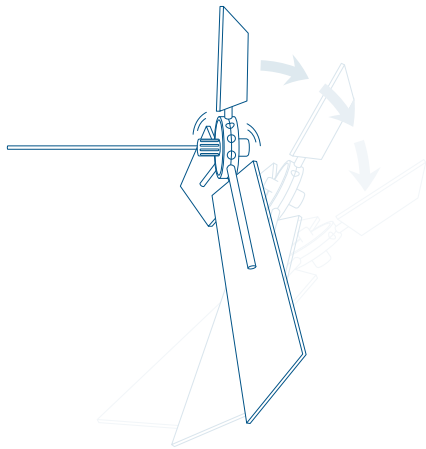

The hub is designed to have a very tight fit to the Quick Connect, but if your blades are unbalanced or your turbine is not directly facing the wind, it may come loose. Be careful with blades that are out of balance.

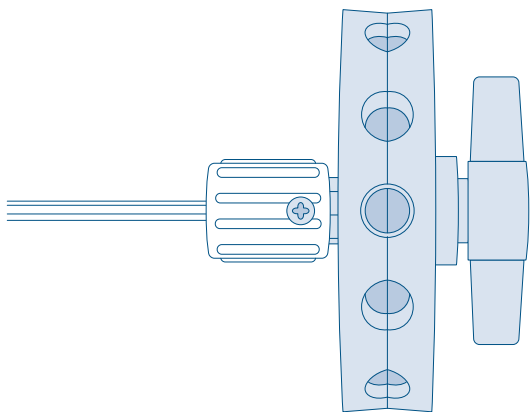

You can use an extra nacelle screw as a set screw, if you need the hub to be more firmly fixed to the driveshaft.

4. The 16-, 32-, or 64-tooth gear will attach onto the hex lock. You can choose to mount the gear on either side of the nacelle, but we recommend mounting your gears on the opposite side of the nacelle. This makes it easier to interchange gears and manipulate the blade pitch. The final step is to move your DC motor up or down so that the pinion gear meshes with the gear on the driveshaft.

5. The completed nacelle will slide right onto your tower! You can secure the nacelle in place by screwing in one or two more small screws in the holes at the bottom of the nacelle.

### Using the 64-tooth gear (largest ratio)

If you are using the largest gear size, you will notice that it will only fit with regular nuts under the motor mounts, as wingnuts are too tall. If you are using the smallest gear size, you will have to use regular nuts above the motor mounts. Give the hub a spin to make sure that the gear turns and rotates the small pinion gear on the motor.

### Using the 16-tooth gear (smallest ratio)

Since the 16-tooth gear is so small, it is challenging to get the generator high enough in the main body to mesh gears. In order to use this small ratio, you have to use the thinner generator. Remove the upper half of the motor mount and slide a small cardboard or folded paper shim in between the generator and the main body housing. You will have to adjust the width of this shim to get the gears to mesh perfectly.

Tighten the nuts below the motor mount to secure the generator in place. If the gears do not mesh well, adjust your shim.

### Hex Lock and the Hub Quick Connect

1. The hex-shaped driveshaft allows you connect the hex lock to the driveshaft. If you mount your gears or a weightlifting spool (p. 9) on the back of the nacelle, the hex lock will not slip on the driveshaft.
2. The Hub Quick Connect (HQC) allows for easy removal and attachment of the hub. This enables users in busy classroom environments to change blade configurations quickly and easily.

Strong wind, large or out of balance turbine blades and worn out can make the HQC unstable.

There are a couple easy solutions if your hub is falling off the HCQ. Adjust your blades to make sure their weight, pitch, size, and shape are all equal so that your rotor is well balanced. Pushed the hub in as far as you can. Glue the hub into the HCQ. The HCQ also has a small hole in which you can insert a screw to hold the hub in place.



# Configuring your Advanced Wind

## Experiment Kit

### Advanced Wind Experiment Kit weightlifter

Lifting weights with your wind turbine is another great way to explore wind energy. Convert your Advanced Wind Experiment Kit to a weight-lifting turbine. Remove the DC motor and its mount. Leave the hub and driveshaft attached to the nacelle, and push one hex lock onto the driveshaft. Push the wooden spool to lock into this hex lock, then insert the second hex-lock behind the spool. The flange of the hex lock will fit inside the drilled hole of the spool. Tie and tape a string onto the spool. Attach the other end of the string securely to the cup. This cup will hold your weights; a set of metal washers are provided for this purpose. See how much weight you can lift with wind power! Do blades that work well for making electricity also work well for lifting weight?

### Vertical axis (VAWT)

Convert your Advanced Wind Experiment Kit into a Vertical Axis Wind Turbine (VAWT). You will need two motor mounts—one on each side of the nacelle. Place the tower in the rear motor mount, and connect your gears and generator on the same side as the hub. You will have to construct different blades for your VAWT machine—like the H-rotor style shown to the right.

This is a great experiment to compare traditional Horizontal Axis Wind Turbines (HAWT) to Vertical Axis Wind Turbines (VAWT). What are some advantages and disadvantages of each style of turbine?

### The Advanced Wind Experiment Kit dual-generator system

The Advanced Wind Experiment Kit can be set up with a dual-generator system. If you buy another set of motor mounts and nuts and bolts, you can attach a DC motor to the front and back of the nacelle. On the setup pictured, the front motor was producing 12 volts and the rear motor was producing 5 volts.

You can wire the two generators together in series or in parallel. If you connect them in series, your voltage will increase. If you connect them in parallel, your amperage will increase. Before you connect the generators, you need to determine their polarity.

### Advanced Wind Experiment Kit GENPack option

With the optional GENPack kit, you can construct your own generator instead of using one of the stock DC motors! Dive into Faraday's law, AC power generation and electromagnetism to learn about how electricity is generated.

The GENPack fits right into your Advanced Wind Experiment Kit nacelle.

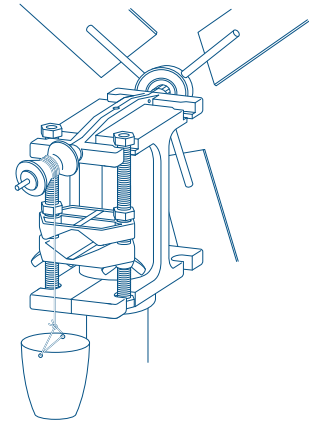

Your Advanced Wind Experiment Kit can also be set up as a weightlifter. Compare the mechanical and electrical power of wind.

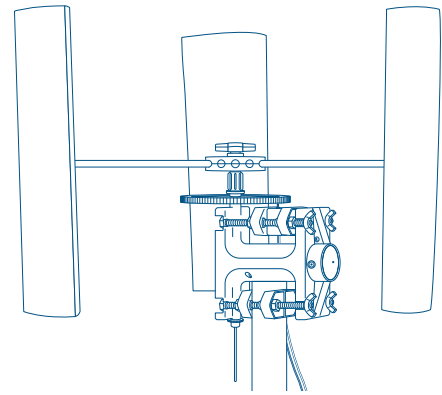

The Advanced Wind Experiment Kit converted to a vertical axis turbine.

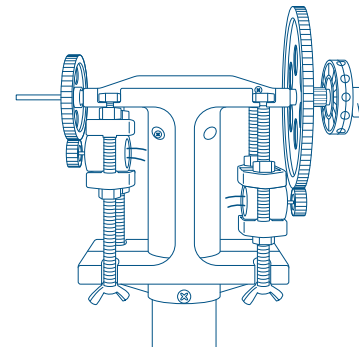

The Advanced Wind Experiment Kit can be set up with two generators.

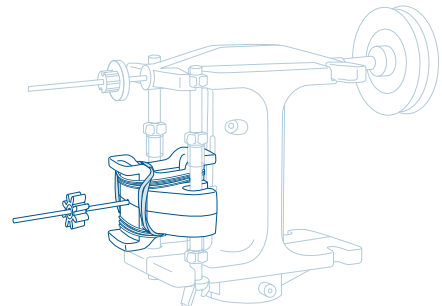

Adding the GENPack expands the experimental value of the Advanced Wind Experiment Kit

## DETERMINING POLARITY

*To determine the proper polarity of your turbine, you will need to connect it to a multimeter. If your voltage reading is positive, the lead connected to the red multimeter wire comes from the positive terminal. If the voltage reading is negative, the lead connected to the red multimeter wire comes from the negative terminal. It is a good idea to mark your wires with tape so you know which is positive and which is negative.*

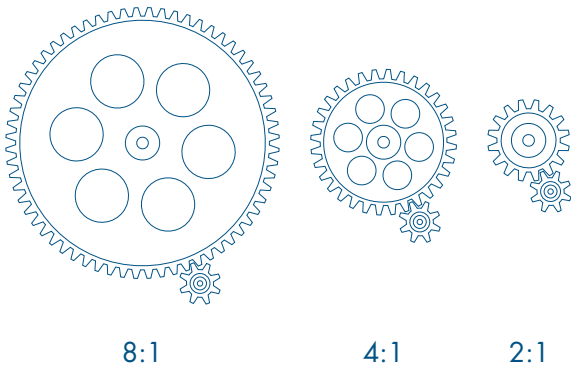

The KidWind Advanced Wind Experiment Kit offers three different gear ratios. The smallest gear attaches to the generator driveshaft and is called the pinion. The pinion gear has 8 teeth. The other three gears attach to the main driveshaft and have 16, 32, or 64 teeth. Do you have to make different blades to run gear ratios?



### CHECK OUT ONLINE VIDEOS FOR HELP!

*For help setting up your Advanced Wind Kit gears, check out a quick video on the subject at [www.KidWind.org/videos](http://www.KidWind.org/videos)*

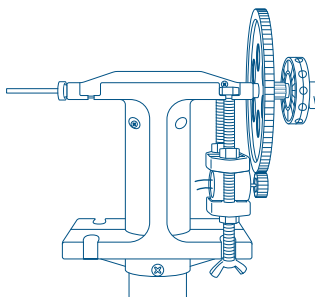

If you are mounting your gear at the front of the nacelle, slide the Hex Lock and your gear up the driveshaft right behind the hub, as shown in the picture below.

Again, be sure to line up the main drive gear with the pinion attached to your DC motor.

It includes a powerful neodymium magnet, copper magnet wire, and a housing to build your generator.

A well-constructed GENPack generator can vastly out-perform the stock generators included in your kit!

## Generators

The DC generator in your wind turbine is actually a DC motor that spins using the energy in the wind. The magnets and wires in the generator transform the energy in the wind into electricity. By manipulating the strength of the magnets used and coils of wire inside the generator, we can affect the power output. In this kit, we provide you with two generators with different technical qualities. Try them both, and compare them. Do some research on electromagnetism or how generators work to learn more!

## Gear ratios

To generate the type of electricity we use every day, the generator has to spin very fast. To summarize the process, the faster the coils rotate near the magnet, the more electrons will be pushed along the wire. If you've seen a utility-scale wind turbine, you probably noticed that the blades spin pretty slowly. So how do they get the generators to spin fast enough? They do this by using gears. Gears give a wind turbine mechanical advantage, and multiply the mechanical force of the turning blades. This is done by using gears with different numbers of teeth. When the larger gear makes one full revolution, the smaller gear has to spin faster to keep up.

A "gear ratio" is the relationship between the number of teeth on two or more gears that are meshed. So when you ride your bicycle, the gear in front might have 48 teeth, while the gear in back has 16 teeth. That would mean every time your pedals spin around once, the back wheel spins three revolutions ( $48 \div 16 = 3$ ). This is called a 3 to 1 (3:1) gear ratio. Wind turbines work the same way except that they have much larger gear ratios. A modern wind turbine may have a gear ratio of 100:1 or more. So every time the blades make one revolution, the generator shaft spins 100 times!

## Troubleshooting

### Why won't the rotor spin when I put my turbine in front of the fan?

Check the orientation of the blades. Are your blades oriented in the same direction? Are they flat? Are they hitting the tower? Look at some pictures of windmills to get some ideas about how to orient your blades.

### Why does the gearbox seem to turn slowly or feel stiff?

The addition of the gearbox adds some friction to the system. Because of

this, you will need to make sure that your blades generate enough *torque* (turning force) to overcome this friction. You can also adjust your generator (move it up or down) to make sure the gears are meshing well. Make sure they are not too tight or too loose!

### **Why does the turbine slow down when I attach it to a load (resistor, pump, bulb, motor)?**

Electrical loads all have some resistance. Resistance “resists” the flow of current. This makes it harder to push electrons through the circuit. The more load you add, the harder it is for the generator to turn and the more torque you must generate from the blades. The best ways to do this are to increase blade pitch, make bigger blades, or find stronger wind.

### **Why are the readings on my multimeter all over the place?**

Your readings may be fluctuating because the wind coming out of your fan is fluctuating. This can also be caused by blades that don't spin smoothly or change shape as they spin. Additionally, your readings will be irregular if your blades are not balanced, evenly distributed, or are producing unequal amounts of drag.

### **Is a fan a good wind source to test with?**

Well, it is the best we've got, unless you have a wind tunnel handy! While a fan will make your turbine spin, it is not exactly like the wind outside. The wind that comes out of a fan has a great deal of rotation and turbulence. It isn't very smooth. To see this turbulence, hold a short piece of thread in front of a fan and move it from the center out. It should head out straight all the time. Does it?

### **Can I take my turbine outside? Can I leave it there?**

You can certainly take, use, and test your wind turbine outside. But unless you have a yawing tower (available from KidWind), it will not track the wind and may not perform optimally. To make it work well, you will have to continually face it into the wind. It is not a good idea to leave your turbine outside for too long. It is designed for basic lab tests, not to endure the rigors of the outdoor environment!

### **Based on the power in the wind equation, it seems that longer blades should make more power. Why isn't this true on my turbine?**

The blades on your turbine may be bigger than the diameter of the fan. If that is the case, the extra length is only adding drag so your blades will slow down. Additionally, large blades are designed poorly, they will have lots of drag near the tips and slow down. This will negate any positive effect of the added length. Also, short blades spin faster than long ones, so if you are just recording voltage they will seem better. Try short blades with a load in series and see if they have enough torque to spin. In many cases they do not!

#### **USING THE 64-TOOTH GEAR (LARGEST RATIO)**

*If you are using the largest gear size, you will notice that it will only fit with regular nuts under the motor mounts, as wingnuts are too tall. If you are using the smallest gear size, you will have to use regular nuts above the motor mounts. Give the hub a spin to make sure that the gear turns and rotates the small pinion gear on the motor.*

#### **USING THE 16-TOOTH GEAR (SMALLEST RATIO)**

*Since the 16-tooth gear is so small, it is challenging to get the generator high enough in the main body to mesh gears. In order to use this small ratio, you have to use the thinner generator. Remove the upper half of the motor mount and slide a small cardboard or folded paper shim in between the generator and the main body housing. You will have to adjust the width of this shim to get the gears to mesh perfectly.*

*Tighten the nuts below the motor mount to secure the generator in place. If the gears do not mesh well, adjust your shim.*

### **My tower is rocking or falling over. How can I stabilize it?**

If your rotor is very large, a strong wind may force your tower to wobble or fall. Try taping the tower base to the floor or to your lab table. Weighting the base with sandbags or other weights can also help.

## *Glossary*

**Current** — Electric current is a measure of the rate at which electric charge (electrons) are flowing through a circuit. It is measured in amperes or “amps” (A).

**Energy** — The capacity to perform work. It is a quantity not a rate. On KidWind turbines we can explore electrical and mechanical energy in joules (J).

**Polarity** — Wires coming from a wind turbine generator are either positive or negative. Which wire is which depends on the direction of rotation of the wind turbine blades. You can determine polarity with a multimeter.

**Multimeter** — A device used to measure voltage, current and resistance.

**Nacelle** — The enclosure at the top of a wind turbine that protects and holds the generator and other important components.

**Resistor** — Electrical resistance is the opposition to the flow of electricity and is measured in ohms ( $\Omega$ ).

**Blade Solidity** — Solidity is the ratio of the blade area to total swept area of the turbine. Solidity can affect the torque and speed of a blade set.

**Torque** — A turning force. The torque your turbine produces is dependent on the wind speed, gearing and size and configuration of your wind turbine blades.

**Ohms ( $\Omega$ )** — Unit of resistance. KidWind turbines usually use resistors in a range of 1–100 ohms.

**Power** — An amount of work per unit of time. Power is a rate, similar to miles per hour, gallons per minute, and dollars an hour.

**Voltage** — Voltage (measured in volts), is a measure of the amount of “potential energy” available to make electricity flow in a circuit. It is the electric “pressure” causing current to flow.

## Multimeter

Using a multimeter, you can quantify the voltage and/or current your turbine is producing. Learning how to accurately measure the voltage and current for a range of situations will help you compare data when testing blades, comparing gearing, or changing any other variables on your Advanced Wind Experiment Kit. You will also need this information if you want to calculate the amount of power your turbine produces.

### Measuring voltage

Attach the wires from the generator to the multimeter. Polarity is not relevant at this point.

To check the voltage, use the dial on the multimeter and select DC volt (V) and set the number to 20.

Place your turbine out in the wind or in front of a fan and let it spin. It is normal for the voltage readings to fluctuate. Voltage output is often unsteady because of unbalanced blades or the inconsistent nature of the wind.

Voltage is related to how fast the DC generator is spinning. The faster it spins, the higher the voltage. When there is no load on the generator, it has little resistance and can spin very fast.

You can measure voltage with no load, but it is more realistic to place a resistor in the circuit and measure the voltage across the resistor. We commonly use 10, 30, 50 or 100 ohm resistors when measuring voltage on KidWind Turbines.

### Measuring current

To calculate your turbine's power output, you will need to measure current as well. To collect amperage data, you will need to place a load, preferably a resistor, in series with the multimeter so that the generator is forced to do some work.

When measuring current, you are monitoring how many electrons are being pushed through the wire by the turbine. We measure current from our turbine in milliAmperes. Recall that  $1\text{A} = 1000\text{mA}$

Build your circuit with a resistor and then place the multimeter in series. Set the meter to 200 or 20 mA, which is a typical range for our devices. If your turbine produces more amperage, you can turn the dial to a higher range.

The current that your turbine produces depends on the load placed in the circuit and the torque your blades are generating.

### Measuring DC Voltage

This meter is measuring 1.5 volts.

### Measuring Current

This meter is measuring 11.8 mA.

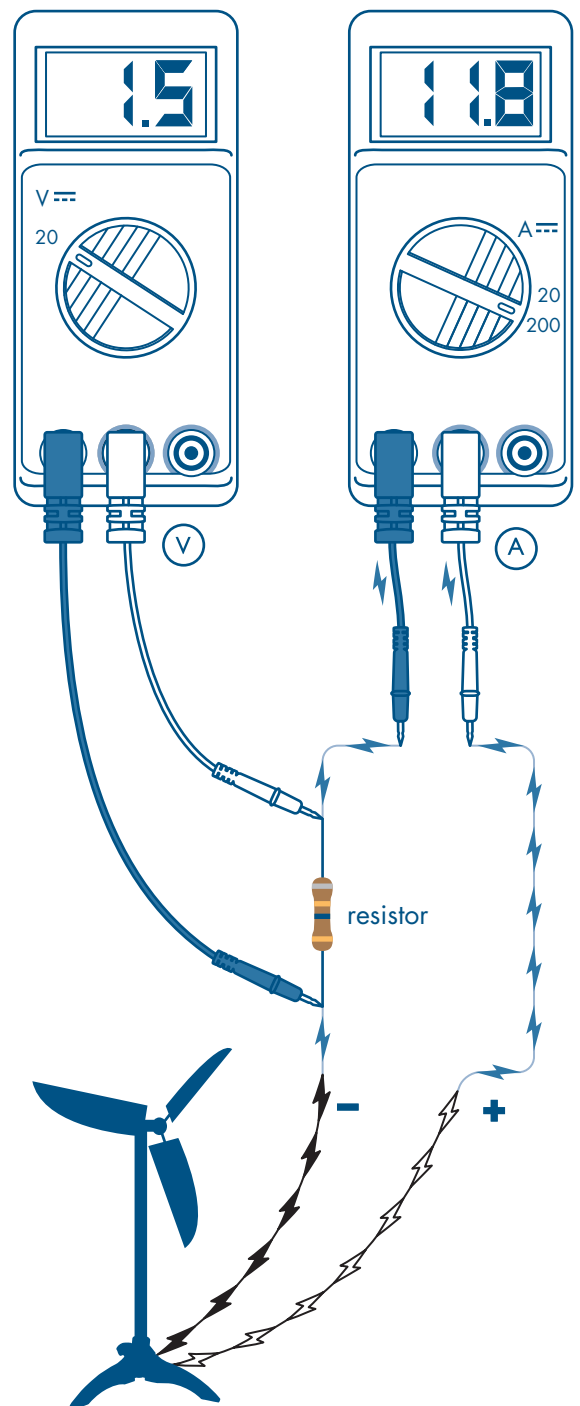

### CHECK OUT LEARN WIND!

*For more information on using your multimeter—and much more—see the Learn Wind document.*

## Simple Experiments

These experiment pages are designed to help you collect data as you perform experiments on your KidWind Turbine. These data sheets will work for any of the turbines we offer, but be sure to read the questions carefully as the responses may vary.

Testing blades on wind turbines can be challenging. Wind turbine blades have a number of things you can change on them at the same time, so collecting data on *one* variable can be challenging. Take your time and do your experiments with care and things will go fine!

1. What variable are you testing (independent variable)? Circle one:

Blade length    Blade pitch    Blade shape    Windspeed    Blade number    Blade weight    Other

What do you predict will happen as you change your variable? Why? \_\_\_\_\_  
 \_\_\_\_\_  
 \_\_\_\_\_

2. Will your turbine be under some kind of load?

Resistor    Water pump    Light bulb    Weights

3. If you are using a resistor, what size are you using? Circle one: 10Ω    30Ω    50Ω    100Ω    Other \_\_\_\_\_

4. What kind of fan are you using? \_\_\_\_\_

5. What is the diameter? \_\_\_\_\_ What is the power setting? \_\_\_\_\_

6. What data are you recording (dependent variable). Circle one:

Voltage    Current    Power    Bolts lifted    Water pumped

### Data collection

Variable tested	Voltage (volts)	Current (amps)	Power (volts x amps)	Other

Dependent variable  
(voltage, current, weight)

Independent variable  
(blade length, pitch, etc.)

### Results

How did your blade variable affect the output of your turbine? \_\_\_\_\_

---

---

---

---

Can you describe why this may be happening? \_\_\_\_\_

---

---

---

---

Do you think you could use the data to improve your next set of blades? What would you do to make them perform better?

---

---

---

---

---



800 Transfer Road, St. Paul, MN 55114  
[www.KidWind.org](http://www.KidWind.org) ♦ Phone: 877.917.0079  
Fax: 208.485.9419

© Copyright 2013 All rights reserved