

**Technical Specifications for**

**6500 Series Sonar Ranging Module**

Part# 615077-Minimum order 10, increments of 10

**Features:**

- Accurate Sonar Ranging from 6" to 35 ft.
- Drives 50 kHz Electrostatic Transducer with No Additional Interface
- Operates from Single Supply
- Accurate Clock Output Provided for External Use
- Selective Echo Exclusion
- TTL-Compatible
- Multiple Measurement Capability
- Uses TI TL851 and Polaroid 614906 Sonar Chips
- Socketed Digital Chip
- Convenient Terminal Connector
- Variable Gain Control Potentiometer

**Description:**

The 6500 Series is an economical sonar ranging module that can drive all Polaroid electrostatic transducers with no additional interface. This module, with a simple interface, is able to measure distances from 6" to 35 ft. The typical absolute accuracy is  $\pm 1\%$  of the reading over the entire range.

This module has an external blanking input that allows selective echo exclusion for operation on a multiple echo mode. The module is able to differentiate echos from objects that are only 3" apart. The digitally controlled-gain, variable-bandwidth amplifier minimizes noise and side-lobe detection in sonar applications.

The module has an accurate ceramic resonator-controlled 420 kHz time-base generator. An output based on the 420 kHz time base is provided for external use. The sonar transmit output is 16 cycles at a frequency of 49.4 kHz.

The 6500 Series module operates over a supply voltage range from 4.5 volts to 6.8 volts and is characterized for operation from 0° C to 40° C.

**Absolute Maximum Ratings:**

Voltage from any pin to ground (see Note 1) .....	7 V
Voltage from any pin except XDCR to Vcc (see Note 1) .....	-7 to 0.5 V
Operating free-air temperature range .....	0° C to 40° C
Storage temperature range .....	-40° C to 85° C

NOTE 1: The XCDR pin may be driven from -1 volt to 400 volts typical with respect to ground

Specifications subject to change without notice.

**Recommended Operating Conditions**

	MIN.	MAX.	UNIT
Supply Voltage, Vcc	4.5	6.8	V
High-level Input Voltage, V <sub>IH</sub>	2.1		V
Low-level Input Voltage, V <sub>IL</sub>		0.6	V
ECHO and OSC Output Voltage		6.8	V
Delay Time, Power Up to INIT High	5		ms
Recycle Period	80		ms
Operating Free-air Temperature, T <sub>A</sub>	0	40	° C

For additional information, technical assistance or prices and delivery:

Polaroid OEM Components Group  
Tel: (617) 386-3965 Fax: (617) 386-3966

# 6500 Series Sonar Ranging Module (Cont.)

Electrical Characteristics Over Recommended Ranges of Supply Voltage and Operating Free-Air Temperature (unless otherwise noted)

PARAMETER		TEST CONDITIONS	MIN	TYP	MAX	UNIT
Input Current	BLNK, BINH, INIT	$V_I = 2.1 \text{ V}$			1	mA
High-level Output Current, $I_{OH}$	ECHO, OSC	$V_{OH} = 5.5 \text{ V}$			100	$\mu\text{A}$
Low-level Output Voltage, $V_{OL}$	ECHO, OSC	$I_{OL} = 1.6 \text{ mA}$			0.4	V
Transducer Bias Voltage		$T_A = 25^\circ \text{ C}$		200		V
Transducer Output Voltage (peak-to-peak)		$T_A = 25^\circ \text{ C}$		400		V
Number of Cycles for XDCR Output to Reach 400 V		$C = 500 \text{ pF}$			7	
Internal Blanking Interval				2.38†		ms
Frequency During 16-pulse Transmit Period	OSC output			49.4†		kHz
	XMIT output			49.4†		
Frequency After 16-pulse Transmit Period	OSC output			93.3†		kHz
	XMIT output			0		
Supply Current, $I_{CC}$	During transmit period				2000	mA
	After transmit period				100	

†These typical values apply for a 420 kHz ceramic resonator.

## Operation With Polaroid Electrostatic Transducer:

There are two basic modes of operation for the 6500 Series sonar ranging module: single-echo mode and multiple-echo mode. The application of power ( $V_{CC}$ ), the activation of the Initiate (INIT) input, and the resulting transmit output, and the use of the Blanking Inhibit (BINH) input are basically the same for either mode of operation. After applying power ( $V_{CC}$ ) a minimum of 5 milliseconds must elapse before the INIT input can be taken high. During this time, all internal circuitry is reset and the internal oscillator stabilizes. When INIT is taken high, drive to the Transducer XDCR output occurs. Sixteen pulses at 49.4 kHz with 400-volt amplitude will excite the transducer as transmission occurs. At the end of the 16 transmit pulses, a DC bias of 200 volts will remain on the transducer as recommended for optimum operation.

In order to eliminate ringing of the transducer from being detected as a return signal, the Receive (REC) input of the ranging control IC is inhibited by internal blanking for 2.38 milliseconds after the initiate signal. If a reduced blanking time is desired, then the BINH input can be taken high to end the blanking of the Receive input anytime prior to internal blanking. This may be desirable to detect objects closer than 1.33 ft. corresponding to 2.38 milliseconds and may be done if transducer damping is sufficient so that ringing is not detected as a return signal.

In the single-echo mode of operation (Figure 1), all that must be done next is to wait for the return of the transmitted signal, traveling at approximately 0.9 milliseconds per foot out and back. The returning signal is amplified and appears as a high-logic-level echo output. The time between INIT going high and the Echo (ECHO) output going high is proportional to the distance of the target from the transducer. If desired, the cycle can now be repeated by returning INIT to a low-logic level and then taking it high when the next transmission is desired.

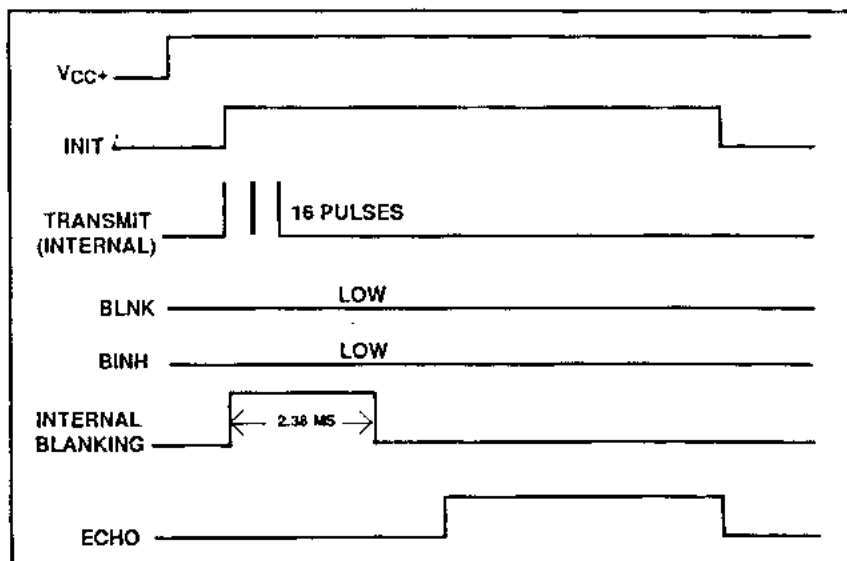
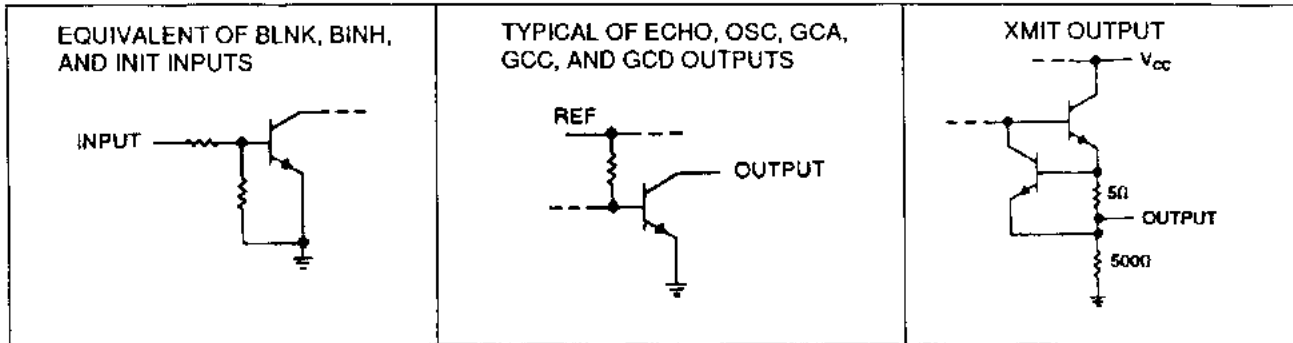

FIGURE 1: EXAMPLE OF A SINGLE-ECHO-MODE CYCLE WITHOUT BLANKING INPUT

# 6500 Series Sonar Ranging Module (Cont.)

## Schematic Equivalents Circuits of Board Inputs/Outputs



**INPUT/OUTPUT SCHEMATICS** NOTE: The echo output is an open collector transistor output and requires a 4.7 k ohm pull up resistor between Vcc and the output.

If there is more than one target and multiple echos will be detected from a single transmission, then the cycle is slightly different (Figure 2). After receiving the first return signal which causes the ECHO output to go high, the Blanking (BLNK) input must be taken high then back low to reset the ECHO output for the next return signal. The blanking signal must be at least 0.44 milliseconds in duration to account for all 16 returning pulses from the first target and allow for internal delay times. This corresponds to the two targets being 3" apart.

During a cycle starting with INIT going high, the receiver amplifier gain is incremented higher at discrete times (Figure 3) since the transmitted signal is attenuated with distance. At approximately 38 milliseconds, the maximum gain is attained. For this reason, sufficient gain may not be available for objects greater than 35 ft. away. Although gain can be increased by varying R1 (Figure 4), there is a limit to which the gain can be increased for reliable module operation. This will vary from application to application. The modules are "kitted" prior to their final test during manufacture. This is necessary because the desired gain distribution is much narrower than the module gain distribution if all were kitted with one value resistor. As kitted, these modules will perform satisfactorily in most applications. As a rule of thumb, the gain can be increased up to a factor of 4, if required, by increasing R1 correspondingly. Gain is directly proportional to R1.

Potentiometer VR1 (Figure 4) provides an interstage gain adjustment for the module. It can be used to trim the overall range of gain set by fix resistor R1.

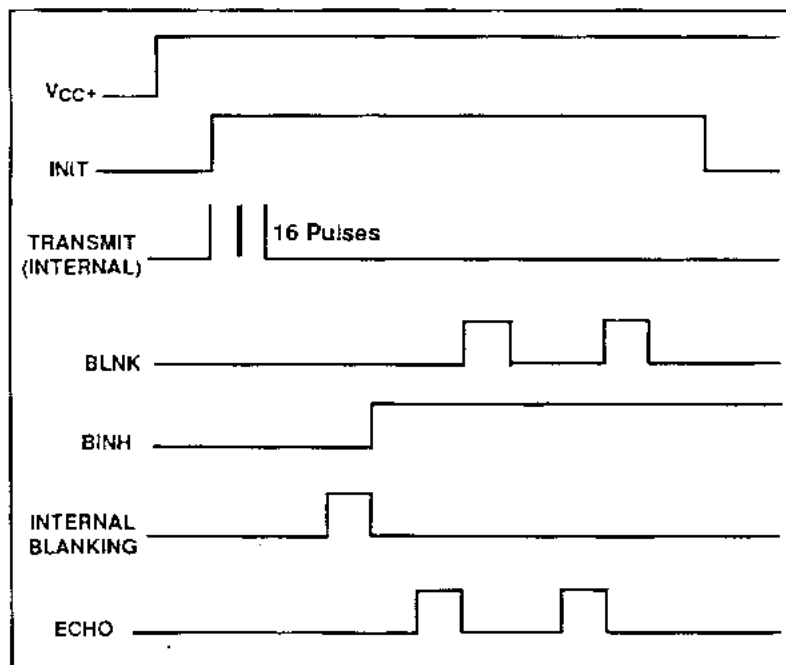

FIGURE 2: EXAMPLE OF A MULTIPLE-ECHO-MODE CYCLE WITH BLANKING INPUT

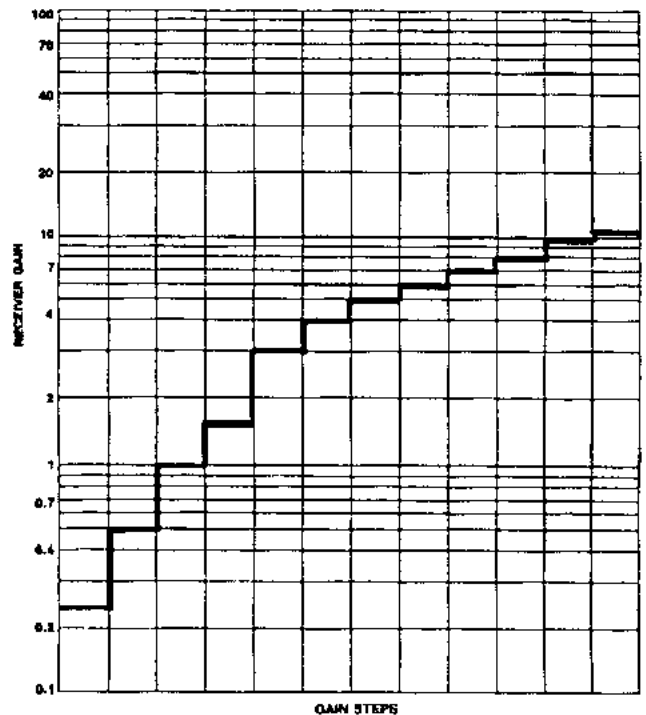

FIGURE 3: RECEIVER GAIN VS GAINSTEP NUMBERS

# 6500 Series Sonar Ranging Module (Cont.)

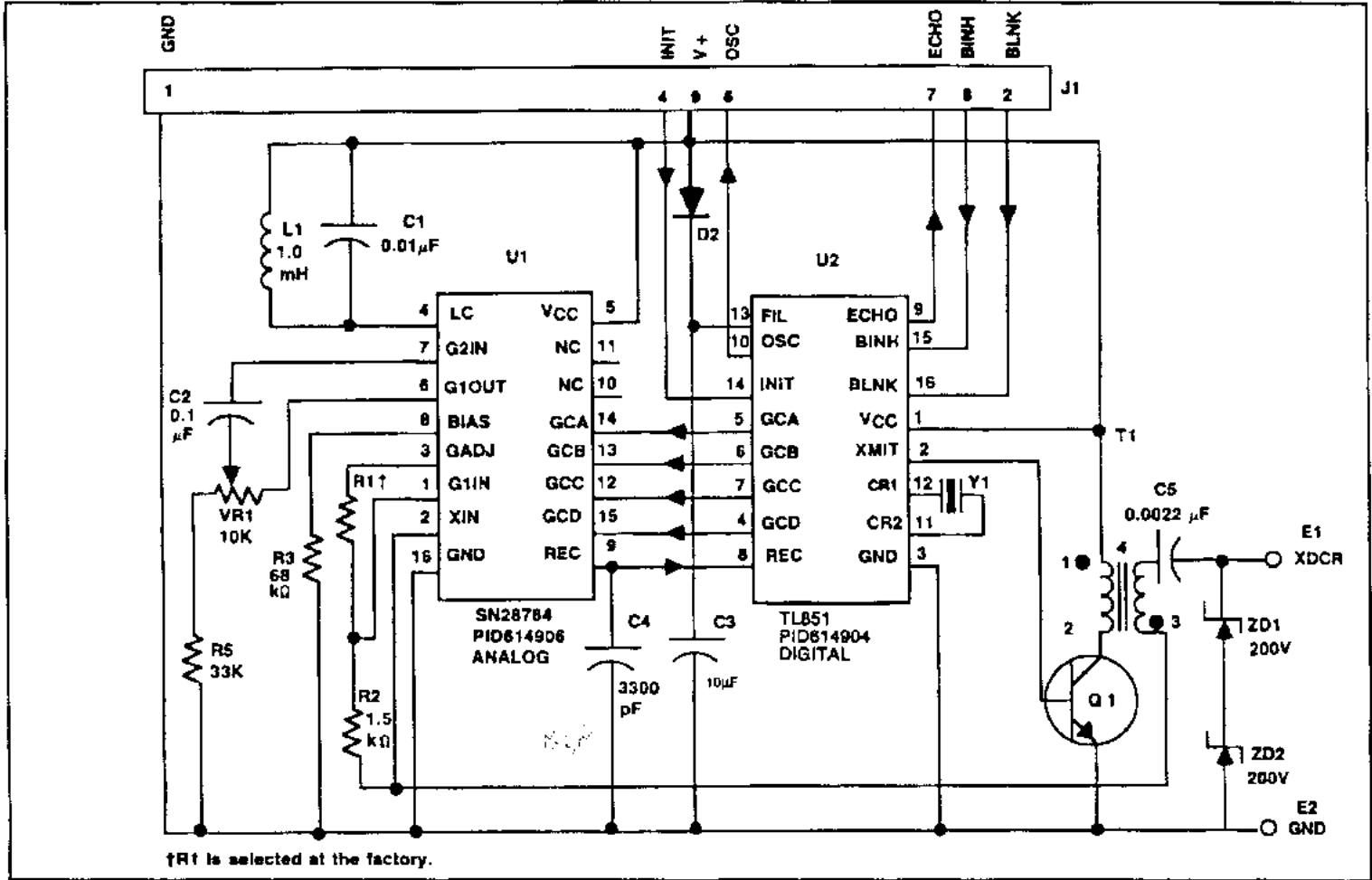

FIGURE 4: SCHEMATIC

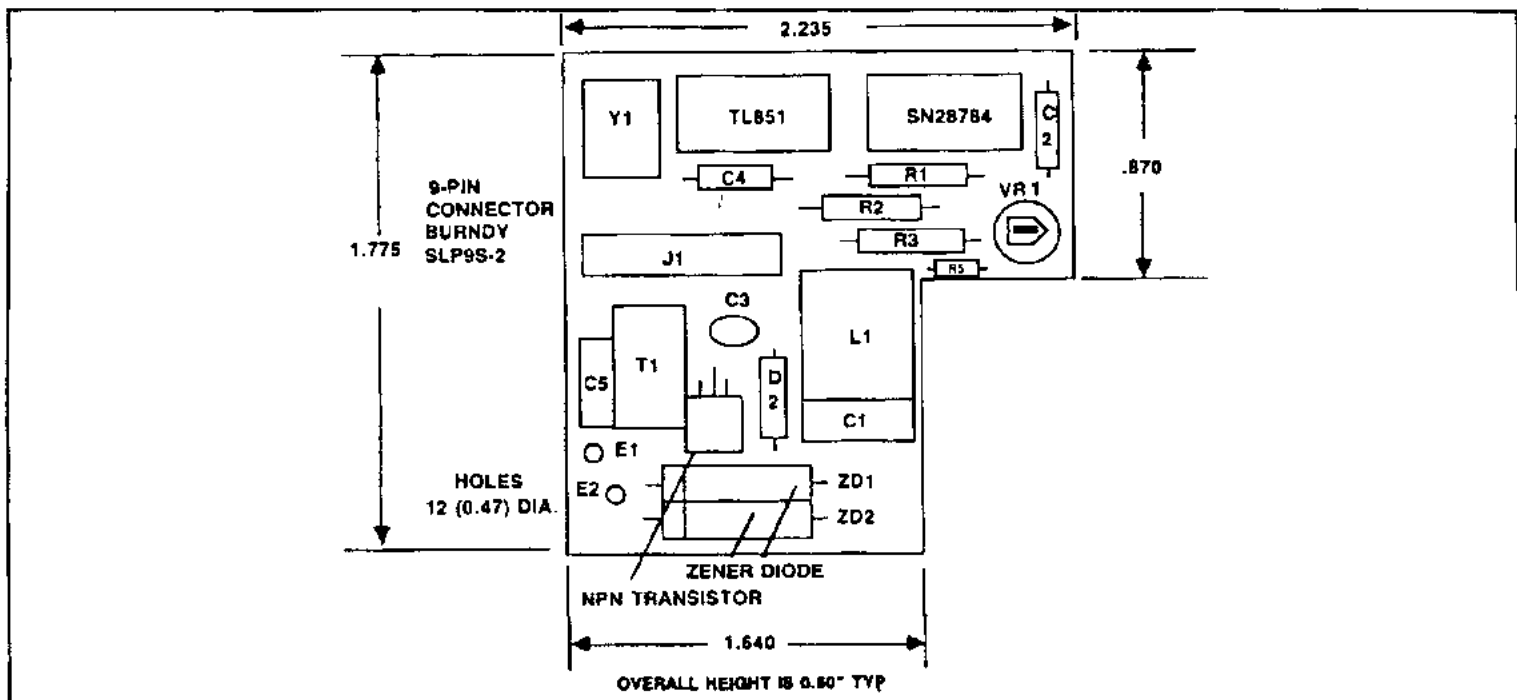

FIGURE 5: COMPONENT LAYOUT AND DIMENSIONS OF MODULE